

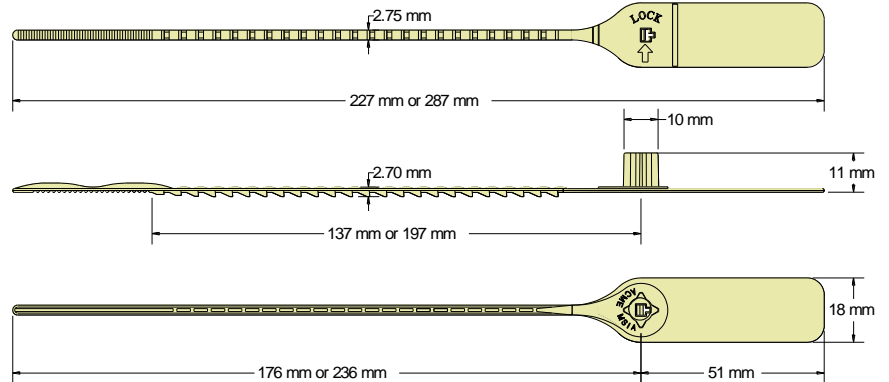

M SEAL Data Sheet

Acme Reg No: 1703011



The Acme **M Seal** is a pull tight seal manufactured from Polypropylene material. The locking action is very similar to the tried and tested Minitight (now discontinued) but has the contours of the smooth X Seal. The design offers a cost effective solution for applications where strength is not the primary requirement, but is ideal for use as an indicative seal.

Technical Data

Recommended Applications

Airlines, Refineries, Warehouses, Cash bags, Postbags, Mailrooms, Bar boxes, Fire doors, Lockers.

Material

Polypropylene with Biodegradable additives

Available Operating Length

(L1) 17.6cm (overall 23cm)
(L2) 23.6cm (overall 29cm)

Strap Width

2.75mm

Average Application Breaking Strength

12kg

Marking

Laser or Foil marking
Consecutively numbered as standard
Optional Customer name/logo
Optional Laser Barcoding

Colours

Foil marked: red, blue, green, yellow, orange, black, white.
Laser or Foil marked: pastel shades of pink, blue, green, yellow, peach, also black and white.
Other colours may be available on request.

Packaging

Standard Packaging : 10 per mat and 1,000 seals/carton
Carton Dimensions : (L1) - 28cm x 20cm x 24cm
: (L2) - 32cm x 20cm x 24cm
Carton weight : (L1) - 2.55kg/carton
: (L2) - 2.85kg/carton

